

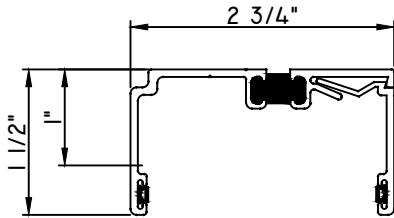

## 2 3/8" ACCESSORIES



### RECEPTOR & CLIP

MAX17296 - RECEPTOR  
 MAX2274 - CLIP  
 PN-2930 - RECEPTOR W.S.  
 PN-2930 - CLIP W.S.

**MUST BE USED WITH SUBSILL:**

M15877

**INSTALL TYPE:**

SQUARE CUT IN FIELD

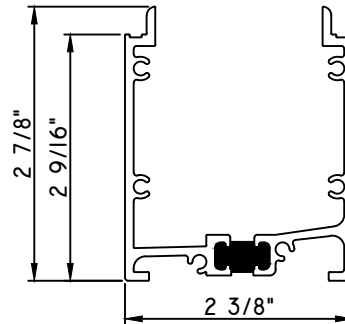

### SUBSILL

M15877 - SUBSILL  
 QWP-15877 - END DAM (QTY. 2)  
 BRBTT46 - POP RIVET (QTY. 12)

**MUST BE USED WITH RECEPTOR MAX17296**

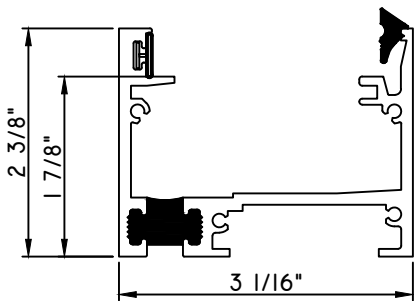

### SUBSILL

M19934 - SUBSILL  
 BPN-9159 - W.S.  
 4874-02-00-19 - WEDGE GASKET  
 19934 - END DAM (QTY. 2)  
 BRBTT46 - POP RIVET (QTY. 8)  
 1211 - WEEP COVERS

**MUST BE USED WITH RECEPTOR M18141**

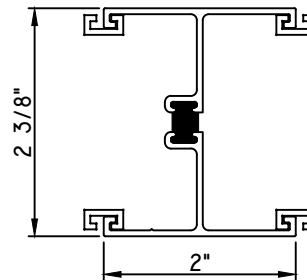

### STACK MULL

MAX1700 - STACK MULL  
 M6270 - C-MULL (QTY. 2 OR 4)

**FACTORY APPLIED INSTALL ONLY**

## 2 3/8" ACCESSORIES

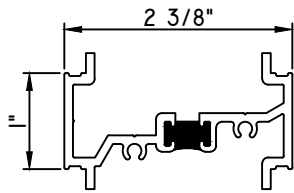

### 1" STACK MULL

MW25615 - STACK MULL  
970-300 - WEEP COVER

**FIELD APPLIED INSTALL ONLY**

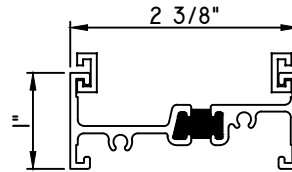

### 1" STACK MULL

M43325 - STACK MULL  
QWP-43325 - END DAMS (QTY. 2)  
BRBTT46 - POP RIVET (QTY. 4)  
970-300 - WEEP COVER

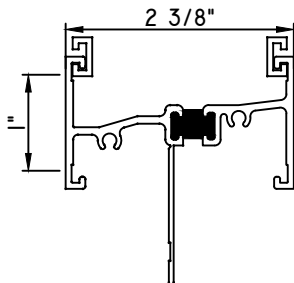

### 1 3/8" STACK MULL

MW23712 - STACK MULL  
QWP-070706 - END DAMS (QTY. 2)  
BRBTT46 - POP RIVET (QTY. 4)  
970-300 - WEEP COVER

**FACTORY APPLIED INSTALL ONLY**



**QUAKER**  
COMMERCIAL

## 2 3/8" ACCESSORIES

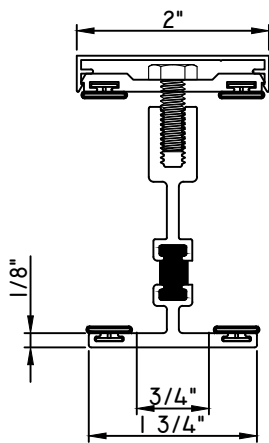

### T-MULL

- M16690 - T-MULL
- MAX17386 - BASE
- MAX14141 - CAP
- BPN-9159 - W.S. (QTY. 4)
- MH1/4 20X3/4 - BOLTS (18" APROX. O.C.)
- M13404 - L-ANGLE (QTY. 2)
- MPS-8X1 1/2 - FASTENERS (QTY. 4)

**MUST BE USED WITH STANDARD  
2 3/8" RECEPTOR & SUBSILL**

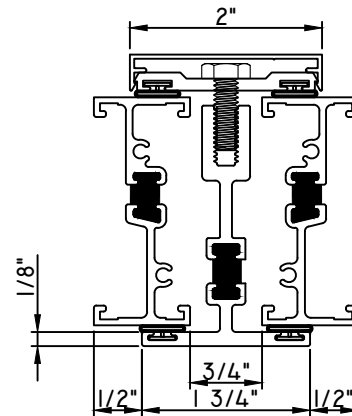

### T-MULL/1" STACK LEFT/RIGHT

- M16690 - T-MULL
- MAX17386 - BASE
- MAX14141 - CAP
- 1" STACK MULL - M43325 LEFT/RIGHT
- BPN-9159 - W.S. (QTY. 4)
- MH1/4 20X3/4 - BOLTS (18" APROX. O.C.)
- M13404 - L-ANGLE (QTY. 2)
- MPS-8X1 1/2 - FASTENERS (QTY. 4)

**MUST BE USED WITH STANDARD  
2 3/8" RECEPTOR & SUBSILL**



**QUAKER**  
COMMERCIAL

## 2 3/8" ACCESSORIES

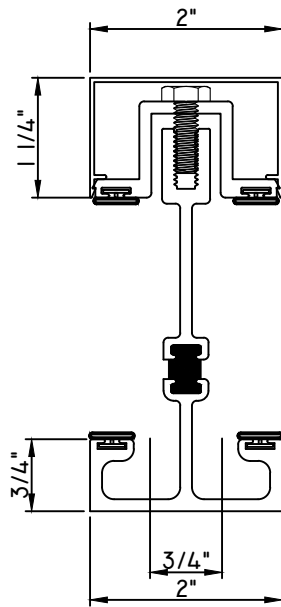

### T-MULL

- M536203 - T-MULL
- M14895 - BASE
- M14896 - CAP
- BPN-9159 - W.S. (QTY. 4)
- MH1/4 20X3/4 - BOLTS (18" APROX. O.C.)
- M13404 - L-ANGLE (QTY. 2)
- MPS-8X1 1/2 - FASTENERS (QTY. 4)

**MUST BE USED WITH STANDARD  
2 3/8" RECEPTOR & SUBSILL**

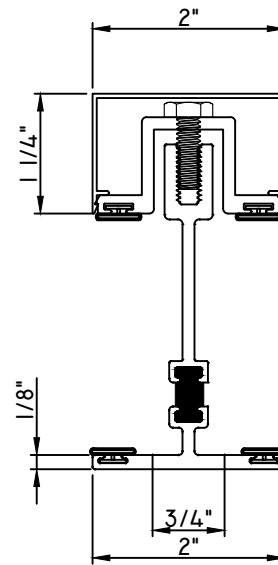

### T-MULL

- M16875 - T-MULL
- M14895 - BASE
- M14896 - CAP



**QUAKER**  
C O M M E R C I A L

**2  $\frac{3}{8}$ " ACCESSORIES**

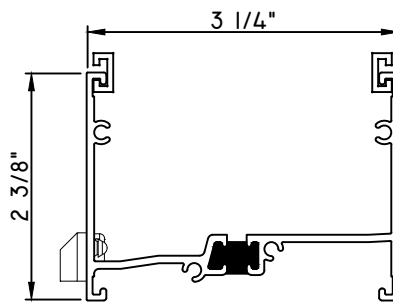

**2  $\frac{3}{8}$ " SUBSILL**  
M22015 - SUBSILL  
970-300 - WEEP COVER